

**Designed.
Engineered.
Remarkable
Value.**

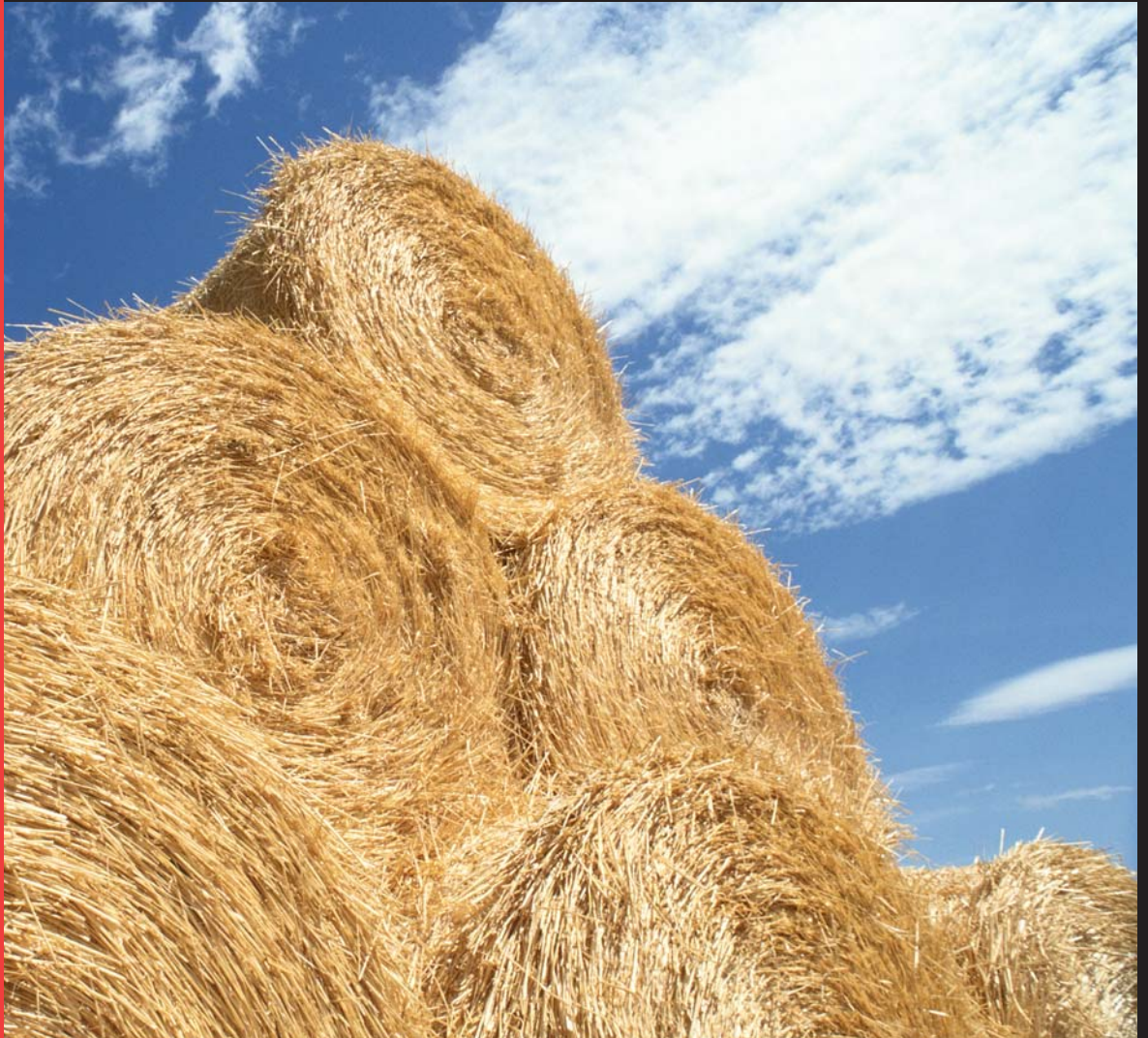

Bale Handling Equipment

**Helping you handle hay in more
than one Worksaver way.**



Worksaver



Choose the Worksaver Way — to Handle Your Hay!

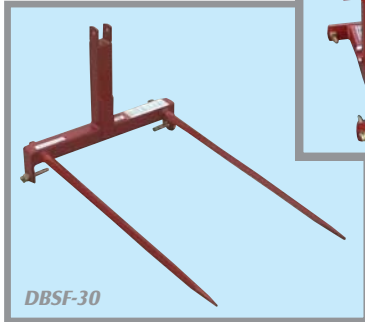

3-pt. Bale Spears

Worksaver has the attachment that is right for your hay handling needs. Our 3-pt. mounted bale spears are designed, depending on model, to handle up to 3,000 lb. bales. The line features tapered “forged” spring steel spears designed for hard center bales allowing easier spear penetration of and withdrawal from bale(s). Each model is designed to mount to Category I/II hitches without a quick hitch.

Model	Item No.	Description	Weight
BSF-1523	830235	Rated for round bales up to 1,800 lbs. Tapered main spear has useable length of 44" with welded balance spears.	57 lbs.
BSFA-20	830920	Adjustable height bale spear rated at 2,000 lbs. Uses bolt-in tapered main spear, useable length of 44" with welded balance spears.	78 lbs.
BSF-122	830935	Rated for round bales up to 2,200 lbs. Tapered main spear has useable length of 44", machined balance spike is 16" in length.	72 lbs.
DBSF-30	830770	Double forged bale spear allows bale to be picked up and not lose its orientation. Uses two tapered spears with 44" useable length.	78 lbs.

3-pt. Bale Forks

In need of a tool to lift heavy bales? These bale forks can perform that task. Both models have patented, internally strengthened forks that feature triple-tapered fork points. Each fork also has a stabilizer spike.



Model	Item No.	Description	Weight
F-1511	830030	3-pt. Bale Fork rated at 1,500 lbs. Forks are 55" in length, spaced 37.5" apart. Fits Cat. I/II as well as Cat. II Quick Hitch.	144 lbs.
F-3000	830101	3-pt. Bale Fork rated at 3,000 lbs. Forks are 55" in length, spaced 46.5" apart. Fits Cat. II as well as Cat. II Quick Hitch.	186 lbs.



WARNING: Do not exceed loader or tractor operating lift capacity.



HHU-2045

Bale Unroller & Handler

Ideal for unrolling large round bales for feeding. Allows easy feeding relocation, which reduces manure buildup and provides ample space for livestock to “graze” naturally. The HHU-2045 fits Cat. I/II hitches, as well as Cat. II Quick Hitch.

Model	Item No.	Description	Weight
HHU-2045	831340	3-pt. Hay Handler/Unroller rated at 2,000 lbs. Designed for round bales either 4' or 5' in width up to 6' in diameter (requires a 2.5" x 8" cylinder and hoses, which are not included).	310 lbs.



BBSF-1565

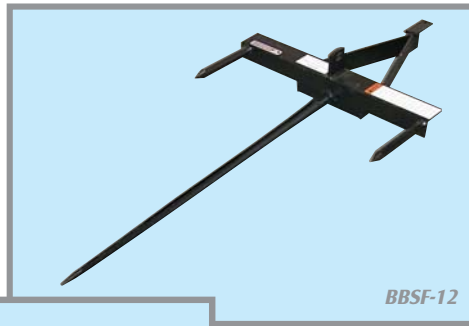

BBSF-12

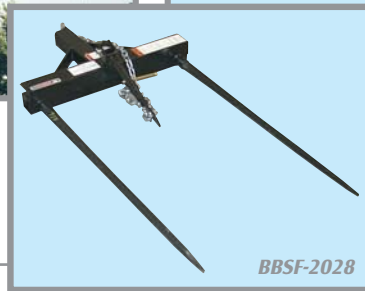

BBSF-2028

Bucket Bale Spears

Quickly convert your front loader bucket into a tool for handling large round bales. Each spear mounts on the bucket cutting edge with heavy angle iron for additional support and utilizes the bucket underside for leverage. The bolt-on or chain system is used to firmly lock the spear on the bucket. These units use tapered “forged” spring steel spears, supported by a special tapered socket.



WARNING: Bale spears are to be inserted into bales. DO NOT use spears as forks.

Model	Item No.	Description	Weight
BBSF-12	831240	Bolt-on Bucket Bale Spear for round bales rated at 1,800 lbs. Tapered spear has useable length of 44". Requires drilling one 17/32" diameter hole in the bucket.	65 lbs.
BBSF-1565	830390	Clamp-on Bucket Bale Spear for round bales rated at 1,800 lbs. Uses single chain & turnbuckle system. Tapered spear has useable length of 44".	76 lbs.
BBSF-2028	830930	Clamp-on Bucket Dual Bale Spear for round bales rated at 2,800 lbs. Uses single chain & turnbuckle system. Tapered spears have useable length of 44". Note: Spears must be inserted into the bale.	101 lbs.

Choose the **Worksaver** Way to Handle Your Hay

Worksaver



Front Loader Bucket Tines

The T-1500 is capable of handling up to 1,500 lb. bales. The triple-tapered points easily slide under the bale. Upright masts & two stabilizer spikes keep bales in place during transport. **NOTE:** Not for use with pallets or spearing bales.



WARNING: Do not exceed loader or tractor operating lift capacity.



Model	Item No.	Description	Weight
T-1500	830400	Clamp-on Bucket Bale Forks, rated at 1,500 lbs. Uses chain & turnbuckle system. Tubular forks are 3" x 2" x 50.75". Uprights, backstop and stabilizer spikes included.	180 lbs.



LSF-18

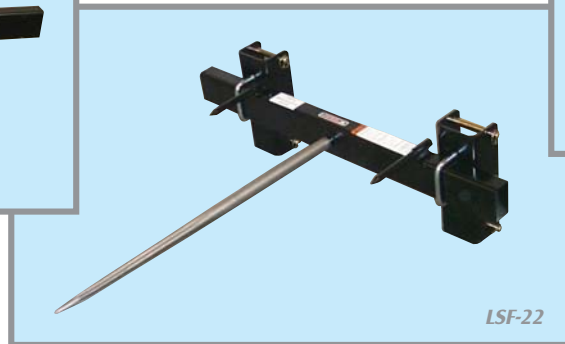

LSF-22



LSF-28

LS-Series Pin-on Type

The LS-Series front loader attachments are designed for pin-on type front loaders only. This economical attachment allows for easy handling of round bales. These attachments are convertible for use on a 3-pt. hitch with the addition of the optional bolt-on ear assembly (not quick hitch adaptable).

Model	Item No.	Description	Weight
LSF-18	832000	Designed for pin-type loaders only this unit is rated at 1,800 lbs. Tapered spear has useable length of 44", unit has two balance spears.	147 lbs.
LSF-22	832005	Designed for pin-type loaders only this unit is rated at 2,200 lbs. Tapered spear has useable length of 44", unit has two balance spears.	152 lbs.
LSF-28	832010	Designed for pin-type loaders only this unit is rated at 3,000 lbs. Dual tapered spears have useable length of 44".	179 lbs.
Optional Bolt-on Assembly			
	831295	Optional bolt-on assembly to allow LSF-18, 22, 28 to be used on a Cat. II 3-pt. hitch.	28 lbs.

UBSF-Series Loader Attachments

The UBSF-Series is designed for use on pin-type front loaders or most popular quick-attach front loader systems using our optional interfacing brackets. These attachments are convertible for use on a 3-pt. hitch with the addition of the optional bolt-on ear assembly (not quick hitch adaptable).

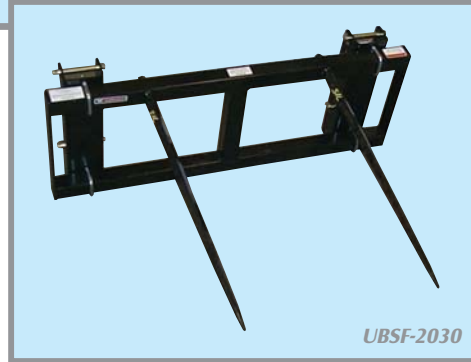

Model	Item No.	Description	Weight
UBSF-2018	831775	Loader Bale Spear, rated at 1,800 lbs. Tapered spear has useable length of 44". Single machined balance spike. Optional interfacing brackets for most quick-attach systems are available.	197 lbs.
UBSF-2022	831778	Loader Bale Spear, rated at 2,200 lbs. Tapered spear has useable length of 44". Single machined balance spike. Optional interfacing brackets for most quick-attach systems are available.	204 lbs.
UBSF-2030	831772	Loader Bale Spear, rated at 3,000 lbs. Dual tapered spears have useable length of 44". Optional interfacing brackets for most quick-attach systems are available.	246 lbs.
Optional Bolt-on Assembly			
	831815	Optional bolt-on assembly allows UBSF attachments to be used on a Cat. II 3-pt. hitch.	17 lbs.

Choose the **Worksaver** Way to Handle Your Hay

Worksaver



RBSF-Series *Loader Attachments*

Handling large or mid-size rectangular bales is easier using one of our models to perform the job. All models feature tapered “forged” spring steel spears. Standard with these are pin-type mounting brackets. Optional interfacing brackets for most popular quick-attach front loader systems are available with loader arm distance of 55” or less. These attachments are convertible for use on a 3-pt. hitch with the addition of the optional bolt-on ear assembly (not quick hitch adaptable).

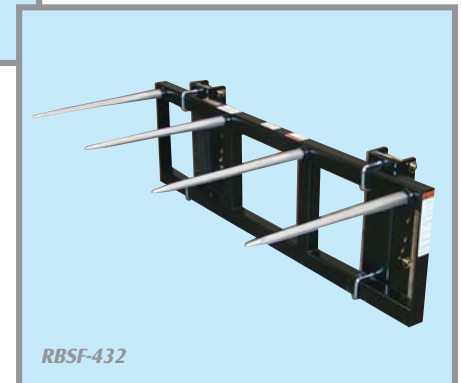
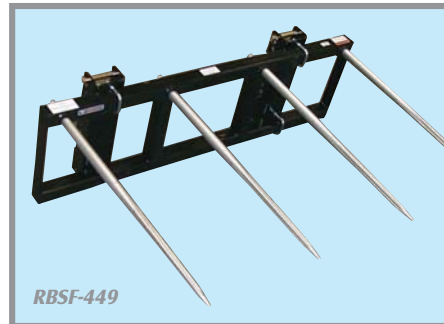
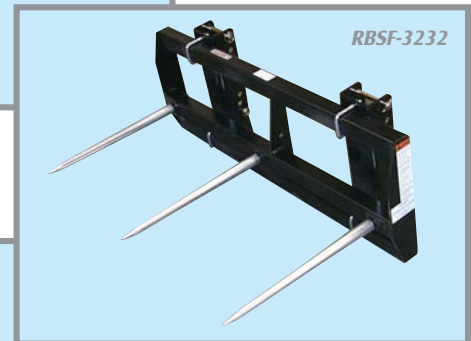
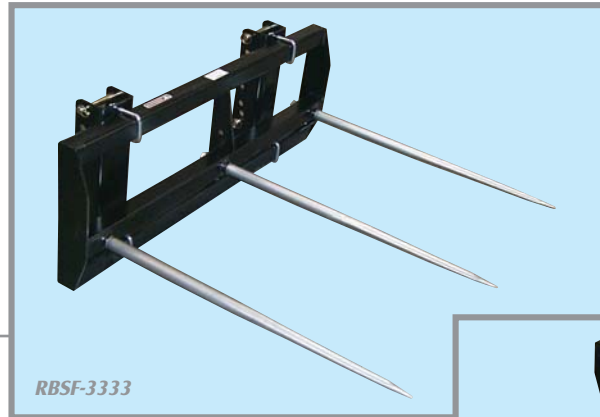

Model	Item No.	Description	Weight
RBSF-3232	830690	Loader Bale Spear, rated at 3,000 lbs. for handling single mid-size square bales. Triple spears have useable length of 26”, spaced 26.5” apart. Use of optional uprights 830693 is required to handle two bales.	246 lbs.
RBSF-3333	830455	Loader Bale Spear, rated at 4,000 lbs. for handling single mid-size square bales. Triple spears have useable length of 44”, spaced 26.5” apart. Use of optional uprights 830693 is required to handle two bales.	279 lbs.
RBSF-449	831495	Loader Bale Spear to handle one rectangular bale. Frame is 72” wide with 4 tapered spears with useable length of 44”. Spaced 22” apart. Optional uprights required to handle two bales.	275 lbs.
RBSF-432	831499	Loader Bale Spear to handle one rectangular bale. Frame is 72” wide with 4 tapered spears with useable length of 26”. Spaced 22” apart. Optional uprights required to handle two bales.	242 lbs.
Optional Bolt-on Uprights & Bolt-on Assembly			
	830693	Optional bolt-on uprights for RBSF-3232/3333 for handling two bales.	69 lbs.
	831491	Optional bolt-on uprights for RBSF-449/432 for handling two bales.	88 lbs.
	831815	Optional bolt-on assembly allows RBSF-series to be used on Cat. II 3-pt. hitch.	19 lbs.



Rectangular Bale Handler

This unit is designed to handle and stack large rectangular bales. Features include heavy-duty UHMW-polyethylene bushings for smooth operation and long service life. Five 26" long "forged" spears are placed along the bottom with six 18" long spears supplied for the uprights providing additional support. Each side features five hooks that are moveable to the most convenient location for handling your bales.

Model	Item No.	Description	Weight
RBH-4000	831460	Large Rectangular Bale Handler, rated at 4,000 lbs. Designed for tractor front loaders. Unit will handle either two 4' x 4' x 8' or three 3' x 3' x 8' rectangular bales. Includes hydraulic cylinder. Optional interfacing brackets for most quick-attach systems available.	881 lbs.

UBH-Series for Wrapped (or Dry) Round Bales

The "Bale Hugger" & "Bale Hand" will gently handle large round wrapped or unwrapped bales with weight up to 2,200 lbs. Both provide smooth curved clamping arms to prevent wrapped bale puncture. Each unit fits most double-cylinder front loaders with load arm distance of 54" or less. Optional interfacing brackets for most quick-attach systems available.



Model	Item No.	Description	Weight
UBH-2000	832850	"Bale Hugger" rated at 2,000 lbs. Designed to handle round bales from 4' to 6'. Features one stationary arm, one opening arm. Hydraulic cylinder included.	435 lbs.
UBH-2072	832940	"Bale Hand" rated at 2,200 lbs. Designed to handle round bales from 4' to 6'. Both arms open to clamp bale. Hydraulic cylinder included.	529 lbs.

Skid Steer Bale Hand for Wrapped (or Dry) Round Bales

The Skid Steer "Bale Hand" gently handles large round wrapped or unwrapped bales. Features smooth curved arms to prevent wrapped bale puncture when clamping. Fits Skid Steer Loaders that utilize the "universal quick-attach" system.

Model	Item No.	Description	Weight
SSBH-2072	832965	Skid Steer "Bale Hand" designed to handle 4' to 6' round bales. Both arms open to clamp bale. Hydraulic cylinder included.	470 lbs.

Skid Steer Bale Handling Attachments

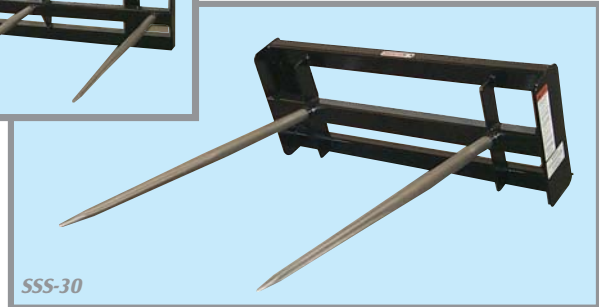

Attachments are designed for the industry standard “universal quick-attach” system. Bale spears are offered to handle large round bales as well as mid-size and large rectangular bales. Optional uprights allow handling of two rectangular bales at a time. All units utilize “forged” spring steel tines for easy spear penetration of the bale.

Model	Item No.	Description	Weight
SSS-22	831150	Skid Steer Bale Spear for round bales, rated at 2,200 lbs. Single tapered spear with useable length of 44”.	134 lbs.
SSS-30	831160	Skid Steer Bale Spear for round bales, rated at 3,000 lbs. Dual tapered spears have useable length of 44”.	158 lbs.
SSRBH-344	831175	Skid Steer Triple Bale Spear for handling large rectangular bales. Triple spears have useable length of 44”, spaced 26.5” apart. Optional bolt-on upright allows handling two bales at once.	235 lbs.
SSRBH-324	831170	Skid Steer Triple Bale Spear for handling mid-size square bales. Triple spears have useable length of 26”, spaced 26.5” apart. Optional bolt-on upright allows handling two bales at once.	205 lbs.
Optional Bolt-on Upright			
	830693	Optional bolt-on uprights for SSRBH allow handing two bales at once.	69 lbs.



Caution — Be sure stabilizer spike is in place when handling large round hay bales with fork-type equipment.

Caution — A heavy load can cause your tractor to tip over. When moving heavy loads, keep the load as close to the ground as possible, go slowly around turns, and be sure the front or rear of tractor is properly counterbalanced with weights.

Caution — Operators must read & understand operator’s manual, particularly the safety warnings and instructions.

The operator is responsible for safety of themselves and others when operating equipment.



WORKSAVER, INC. has a corporate policy of continuous product improvement and development; therefore, specifications are subject to change without any advance notice. WORKSAVER, INC. is not responsible for differences between specifications or illustrations contained in this publication and the actual equipment.

**Designed.
Engineered.
Remarkable
Value.**



Distributed by:

Worksaver, Inc.
P.O. Box 100, Litchfield, IL 62056-0100
Phone: 217-324-5973 • Fax: 217-324-3356
E-mail: sales@worksaver.com
Web: www.worksaver.com